

# Werkzeugkatalog

tool catalogue

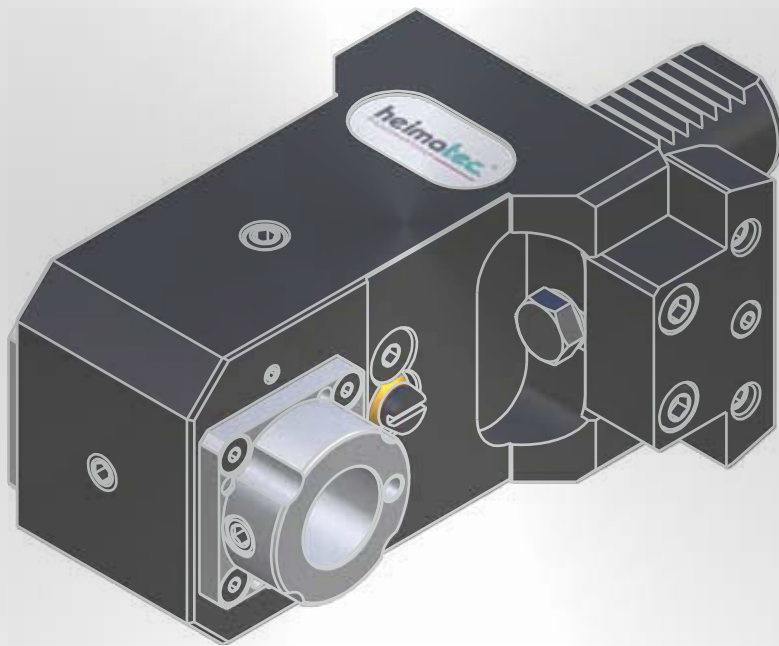

# SPINNER

TC 600 SMCY



Hinweis zu den AGBs:

Diese finden Sie in unserem Internetauftritt unter

[www.heimatec.de](http://www.heimatec.de)

Home/Impressum/AGB

Terms and conditions:

You will find them on our website

[www.heimatec.com](http://www.heimatec.com)

Home/Imprint/Terms and Conditions

Das Katalog-Werk einschließlich aller seiner Teile ist urheberrechtlich geschützt. Jede Verwertung außerhalb der engen Grenzen des Urheberrechtsgesetzes ist ohne Zustimmung der Rechteeinhaber unzulässig und strafbar. Das gilt insbesondere für Vervielfältigungen, Übersetzungen, Mikroverfilmungen und die Einspeicherung und Verarbeitung in elektronischen Systemen.

**heimatec® GmbH** behält sich Änderungen technischer Art jederzeit ohne Vorankündigung vor. Dies gilt insbesondere bei Anpassungen an neue oder geänderte internationale Normen oder bei Weiterentwicklungen unserer Produkte oder Herstellungsprozesse.

This catalogue, including all its parts, is protected by copyright. Each use outside the restricted limitations of the Copyright Act is inadmissible and liable to prosecution without the consent of heimatec. This is particularly valid for duplication, translation, microfilming and feeding and processing in electronic systems.

**heimatec® GmbH** reserves the right of technical changes everytime without advance notice, which is particularly valid for adaptations to new or changed international standards, or to developments of our products or manufacturing processes.

## angetriebene Werkzeuge driven tools



**Axial-Bohr- und Fräskopf**  
axial drilling and milling head

$n_{max} = 8000 \text{ min}^{-1}$

8 010 25 002	ER 25	EK	1:1
8 010 25 063	ER 25	IK 25 bar	1:1
8 010 26 022	easy-quick HT 4	EK	1:1
8 010 26 025	easy-quick HT 4	IK 25 bar	1:1



**Axial-Fräskopf**  
axial milling head

$n_{max} = 8000 \text{ min}^{-1}$

8 011 24 001	Kombidorn/universal arbor 16	EK	1:1
8 011 25 001	Kombidorn/universal arbor 22	EK	1:1



**Winkel-Bohr- und Fräskopf**  
radial drilling and milling head

Mittenmaß / center distance  $H=100$   
links / left

$n_{max} = 8000 \text{ min}^{-1}$

8 030 25 160	ER 25	EK	1:1
8 030 25 161	ER 25	IK 140 bar	1:1
8 030 26 069	easy-quick HT 4	EK	1:1
8 030 26 070	easy-quick HT 4	IK 140 bar	1:1

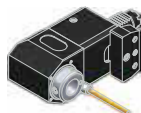

**Winkel-Bohr- und Fräskopf**  
radial drilling and milling head

Mittenmaß / center distance  $H=100$   
rechts / right

$n_{max} = 8000 \text{ min}^{-1}$

8 030 25 173	ER 25	EK	1:1
8 030 25 168	ER 25	IK 140 bar	1:1
8 030 26 072	easy-quick HT 4	EK	1:1
8 030 26 073	easy-quick HT 4	IK 140 bar	1:1



**Winkel-Fräskopf**  
radial milling head

Mittenmaß / center distance  $H=100$   
links / left

$n_{max} = 8000 \text{ min}^{-1}$

8 031 24 042	Kombidorn/universal arbor 16	EK	1:1
8 031 25 034	Kombidorn/universal arbor 22	EK	1:1

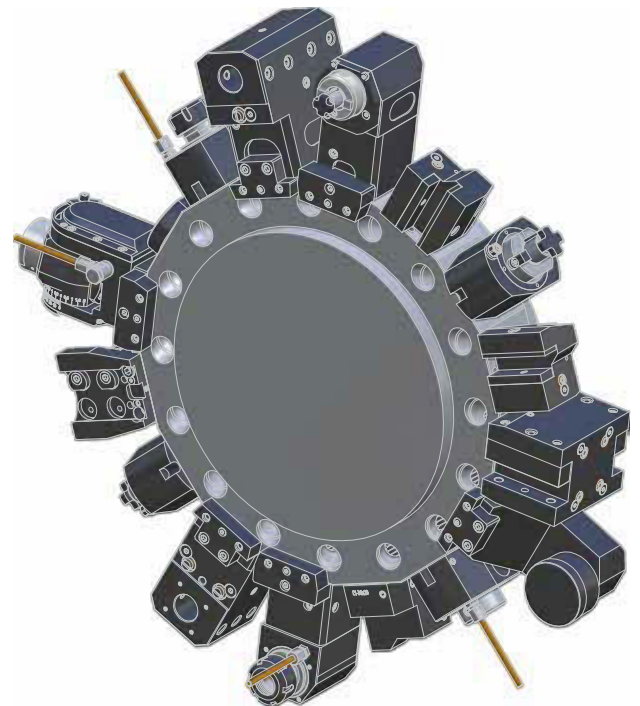

**Winkel-Fräskopf**  
radial milling head

Mittenmaß / center distance  $H=100$   
rechts / right

$n_{max} = 8000 \text{ min}^{-1}$

8 031 24 043	Kombidorn/universal arbor 16	EK	1:1
8 031 25 035	Kombidorn/universal arbor 22	EK	1:1



**Winkel-Bohr- und Fräskopf**  
radial drilling and milling head

Mittenmaß / center distance  $H=110$   
doppelspindlig / double spindle

$n_{max} = 8000 \text{ min}^{-1}$

8 039 25 031	ER 25	EK	1:1
8 039 26 024	easy-quick HT 4	EK	1:1



**Winkel-Scheibenfräserkopf**  
radial disk mill head

Mittenmaß / center distance  $H=103$   
 $n_{max} = 3000 \text{ min}^{-1}$

8 037 29 047	ø8 - ø22	EK	2,55:1
--------------	----------	----	--------



**Schwenkkopf**  
universal head

Mittenmaß / center distance  $H=87$   
 $n_{max} = 8000 \text{ min}^{-1}$

8 040 25 023	ER 25 AX u-tec	EK	1:1
8 040 25 036	ER 25 AX u-tec	IK 140 bar	1:1

► Weitere Ausführungen auf Anfrage  
further versions on request

► Zubehör **ZB...\***  
accessories **ZB...\***

► **easy-quick**

► **u-tec**

**festе Werkzeuge**  
static tool holders



**Werkzeughalter C1**  
tool holder C1

8 214 22 000 **Vierkant/square 20/16** EK

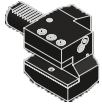

**Werkzeughalter C2**  
tool holder C2

8 215 22 000 **Vierkant/square 20/16** EK

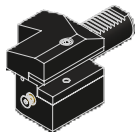

**Werkzeughalter C3**  
tool holder C3

8 214 22 001 **Vierkant/square 20/16** EK



**Werkzeughalter C4**  
tool holder C4

8 215 22 001 **Vierkant/square 20/16** EK

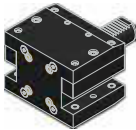

**Kombi-Doppel-Drehstahlhalter**  
combi double turning holder

8 251 24 002 **Vierkant/square 20** EK

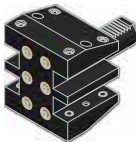

**Mehrfach-Drehstahlhalter**  
multiple turning holder

8 259 22 001 **Vierkant/square 20** EK

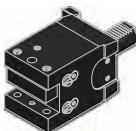

**Kombi-Plandrehhalter**  
combi facing holder

8 234 24 002 **Vierkant/square 20** EK



**Bohrstangenhalter**  
boring bar holder

*Mittenmaß / center distance H=100*  
*links / left*

8 231 27 008 **ø25** IK/EK

8 231 28 009 **ø32** IK/EK

8 231 29 003 **ø40** IK/EK

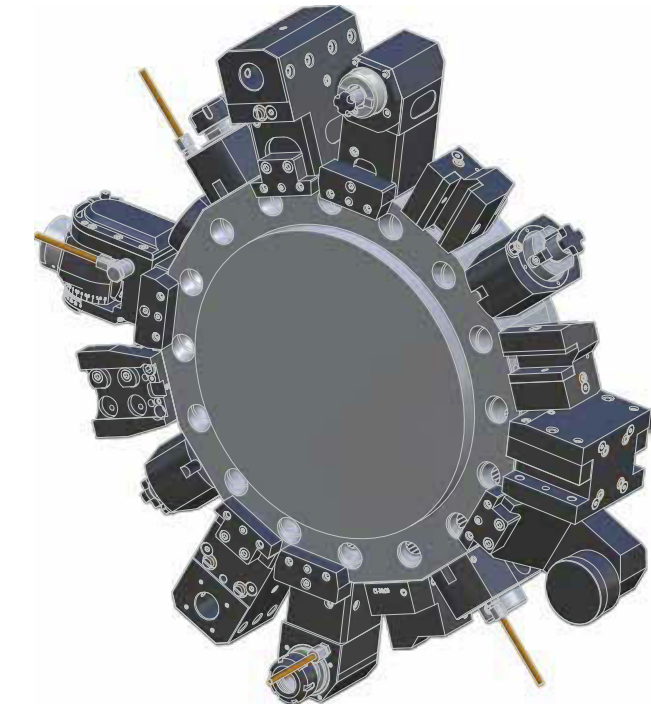

**Bohrstangenhalter**  
boring bar holder

*Mittenmaß / center distance H=100*  
*rechts / right*

8 230 27 027 **ø25** IK/EK

8 230 28 002 **ø32** IK/EK

8 230 29 005 **ø40** IK/EK



**Bohrstangenhalter**  
boring bar holder

*Mittenmaß / center distance H=100*  
*Schwerzerspannung / heavy duty cutting*  
*links / left*

8 231 27 012 **ø25** IK/EK

8 231 28 013 **ø32** IK/EK

8 231 29 007 **ø40** IK/EK



**Bohrstangenhalter**  
boring bar holder

*Mittenmaß / center distance H=100*  
*Schwerzerspannung / heavy duty cutting*  
*rechts / right*

8 230 27 035 **ø25** IK/EK

8 230 28 033 **ø32** IK/EK

8 230 29 011 **ø40** IK/EK

▶ Weitere Ausführungen auf Anfrage  
further versions on request

▶ Zubehör **ZB...\***  
accessories **ZB...\***

▶ **easy-quick**

▶ **u-tec**

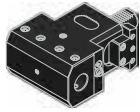

**Doppel-Bohrstangenhalter**  
double boring bar holder

Mittenmaß / center distance H=100

8 239 27 011 2x  $\varnothing$ 25 IK/EK  
8 239 28 009 2x  $\varnothing$ 32 IK/EK

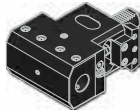

**Doppel-Bohrstangenhalter**  
double boring bar holder

Mittenmaß / center distance H=100  
Schwerzerspannung / heavy duty cutting

8 239 27 015 2x  $\varnothing$ 25 IK/EK  
8 239 28 013 2x  $\varnothing$ 32 IK/EK



**Doppel-Bohrstangenhalter**  
double boring bar holder

Mittenmaß / center distance H=60/102

8 253 27 003 2x  $\varnothing$ 25 IK/EK  
8 253 28 002 2x  $\varnothing$ 32 IK/EK



**Spannzangenhalter**  
collet chuck holder

Mittenmaß / center distance H=100  
links / left

8 231 25 009 ER 25 IK/EK  
8 231 26 015 ER 32 IK/EK

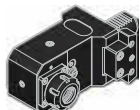

**Spannzangenhalter**  
collet chuck holder

Mittenmaß / center distance H=100  
rechts / right

8 230 25 019 ER 25 IK/EK  
8 230 26 029 ER 32 IK/EK

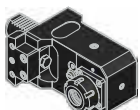

**Spannzangenhalter**  
collet chuck holder

Mittenmaß / center distance H=100  
Schwerzerspannung / heavy duty cutting  
links / left

8 231 25 013 ER 25 IK/EK  
8 231 26 022 ER 32 IK/EK

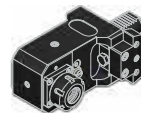
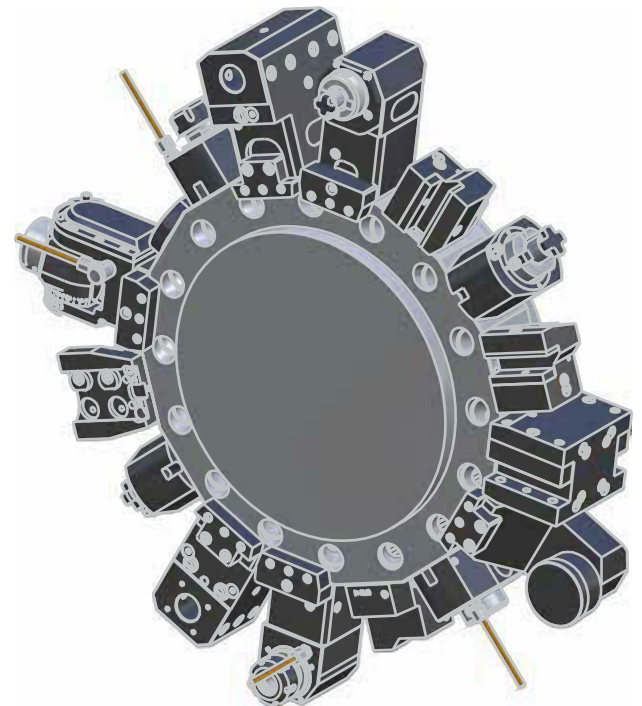

**Spannzangenhalter**  
collet chuck holder

Mittenmaß / center distance H=100  
Schwerzerspannung / heavy duty cutting  
rechts / right

8 230 25 023 ER 25 IK/EK  
8 230 26 036 ER 32 IK/EK



**Doppel-Spannzangenhalter**  
double collet chuck holder

Mittenmaß / center distance H=100  
Schwerzerspannung / heavy duty cutting

8 239 25 018 ER 25 IK/EK  
8 239 26 015 ER 32 IK/EK



**Doppel-Spannzangenhalter**  
double collet chuck holder

Mittenmaß / center distance H=100

8 239 25 022 ER 25 IK/EK  
8 239 26 022 ER 32 IK/EK

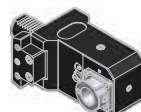



**Aufnahmehalter**  
tool holder

Mittenmaß / center distance H=100  
links / left

8 231 26 018 **easy-quick** HT 4 IK/EK

► Weitere Ausführungen auf Anfrage  
further versions on request

► Zubehör **ZB...**\*  
accessories **ZB...**\* 

► **easy-quick** 

► **u-tec** 

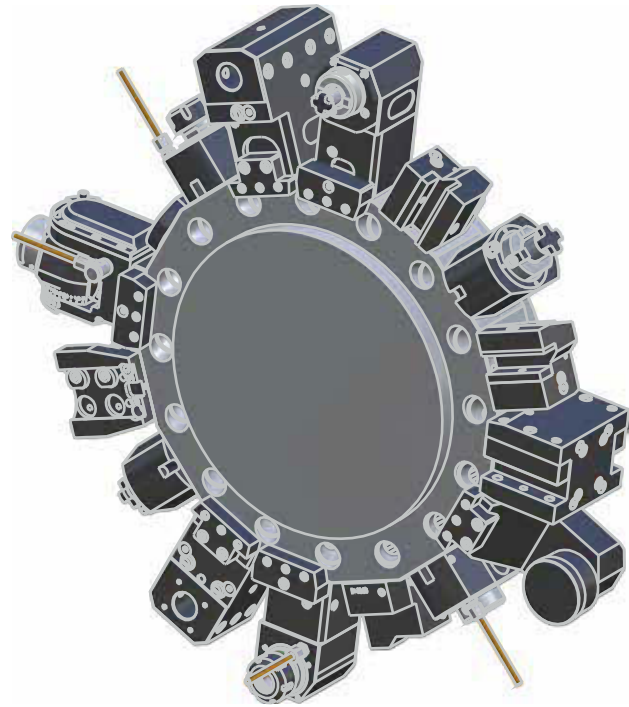

**Aufnahmehalter**  
tool holder

Mittenmaß / center distance H=100  
rechts / right

8 230 26 032 **easy-quick HT 4** IK/EK

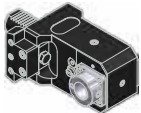

**Aufnahmehalter**  
tool holder

Mittenmaß / center distance H=100  
Schwerzerspannung / heavy duty cutting  
links / left

8 231 26 026 **easy-quick HT 4** IK/EK

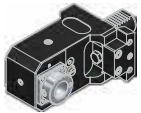

**Aufnahmehalter**  
tool holder

Mittenmaß / center distance H=100  
Schwerzerspannung / heavy duty cutting  
rechts / right

8 230 26 040 **easy-quick HT 4** IK/EK

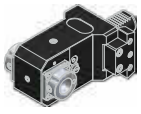

**Doppel-Aufnahmehalter**  
double tool holder

Mittenmaß / center distance H=100

8 239 26 016 **easy-quick HT 4** IK/EK



**Doppel-Aufnahmehalter**  
double tool holder

Mittenmaß / center distance H=100  
Schwerzerspannung / heavy duty cutting

8 239 26 026 **easy-quick HT 4** IK/EK



**Werkstoffanschlag**  
stock stop

Mittenmaß / center distance H=100  
links / left

8 262 29 022 **ø60**



**Abstechhalter**  
cut-off holder

höhenverstellbar / height adjustable  
universal / universal

8 320 23 005 **SH 32** EK

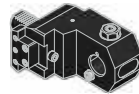

**Adapter für VDI**  
adapter for VDI

Mittenmaß / center distance H=100  
links / left

8 209 22 022 **DIN 69880 - 30** EK



**Adapter für VDI**  
adapter for VDI

Mittenmaß / center distance H=100  
rechts / right

8 209 22 021 **DIN 69880 - 30** EK



**Verschlussstopfen Z2**  
plug Z2

8 200 20 011 **30 K**

8 200 20 005 **30 S**

▶ Weitere Ausführungen auf Anfrage  
further versions on request

▶ Zubehör **ZB...\***  
accessories **ZB...\***

▶ **easy-quick**

▶ **u-tec**

► **easy-quick HT Schnellwechelsystem**  
*easy-quick HT fast change system*

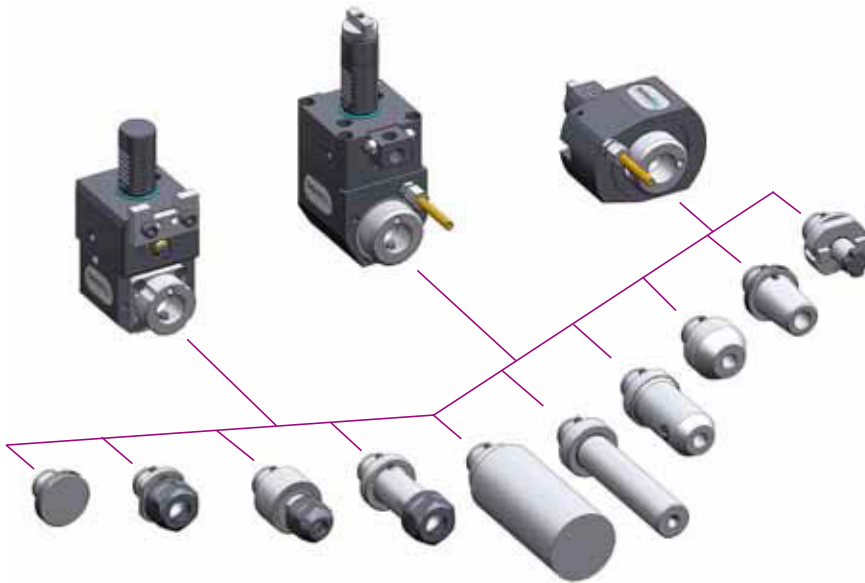

DAS Schnellwechelsystem von heimatec  
für angetriebene und feste Werkzeuge

*THE fast change system of heimatec  
for driven and static tools*

[www.heimatec.de](http://www.heimatec.de)  
Produkte / easy-quick

[www.heimatec.com](http://www.heimatec.com)  
products / easy-quick

► Ausführungen siehe Katalog  
versions see catalogue



► **u-tec<sup>®</sup> UT Wechselsystem**  
*u-tec<sup>®</sup> UT change system*

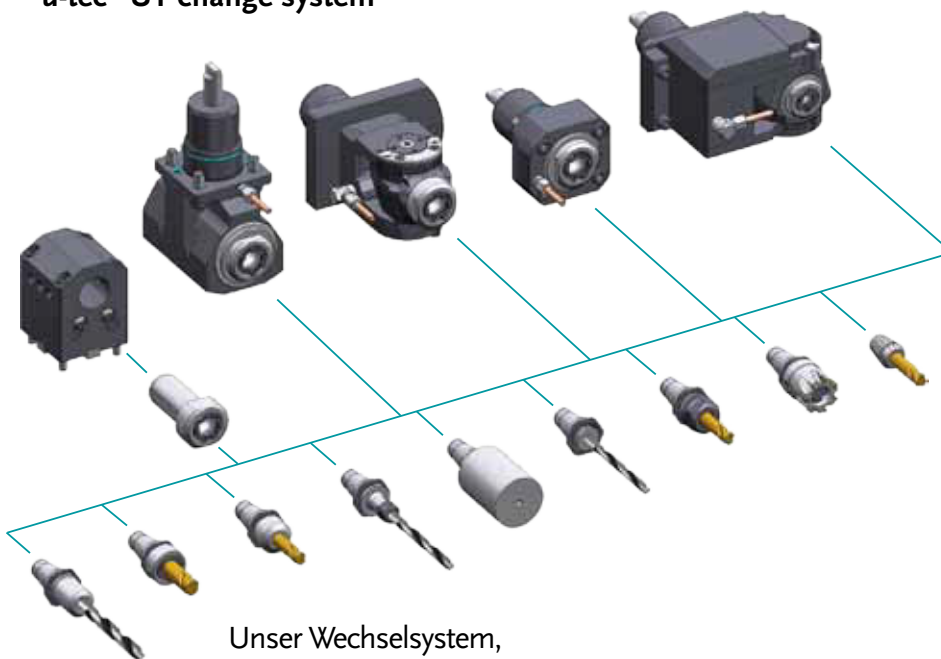

Unser Wechselsystem,  
das ALLES möglich macht

Our change system,  
that makes EVERYTHING possible

[www.heimatec.de](http://www.heimatec.de)  
Produkte / u-tec

[www.heimatec.com](http://www.heimatec.com)  
products / u-tec

► Ausführungen siehe Katalog  
versions see catalogue



# heimatec®

- heimatec®-Niederlassungen  
*heimatec® overseas branches*
- unsere weltweiten Vertretungen  
*global representations of heimatec®*



## Hauptsitz/headquarters

heimatec® GmbH  
Präzisionswerkzeuge  
Carl-Benz-Straße 4  
D- 77871 Renchen  
Postfach 11 36  
D- 77867 Renchen  
Tel.: +49 (78 43) 94 66 0  
Fax: +49 (78 43) 94 66 66  
heimatec.de  
info@heimatec.de

heimatec® Inc.  
USA  
usa.heimatec.com  
USA@heimatec.com

heimatec®-Ost, JSC  
Russia  
ru.heimatec.com  
Russia@heimatec.com

heimatec® Ltd.  
Taiwan  
tw.heimatec.com  
Taiwan@heimatec.com

heimatec®  
Singapore  
sg.heimatec.com  
Singapore@heimatec.com